

AIR MATIC srl
Milano Italy
Cilindro 250 ISO 15552

Pressione max 10 bar (1MPa)
Temperatura max -15 to 70°C NBR / -10 to +180°C PFM
Temperatura fluido -10 to 70°C
Tipo di costruzione Tubo tondo con tiranti zincati a vista

Materiali

testate Ø250 alluminio pressofuso
stelo acciaio C40 cromato
tubo alluminio anodizzato int/ext
guarnizioni NBR/FPM/PTFE

F sviluppata in spinta a 6 bar 29440 N
F sviluppata in trazione a 6 bar 28260 N
Consumo d'aria NI/cm di corsa in spinta 1,407
Consumo d'aria NI/cm di corsa in trazione 1,319
Peso KG 35,5 + 0,0405g per mm di corsa

Forza teorica di spinta $F = (0,785 * P * D^2) / 10$
Forza teorica di trazione $F_t = [(0,785 * P * (D^2 - d^2))] / 10$

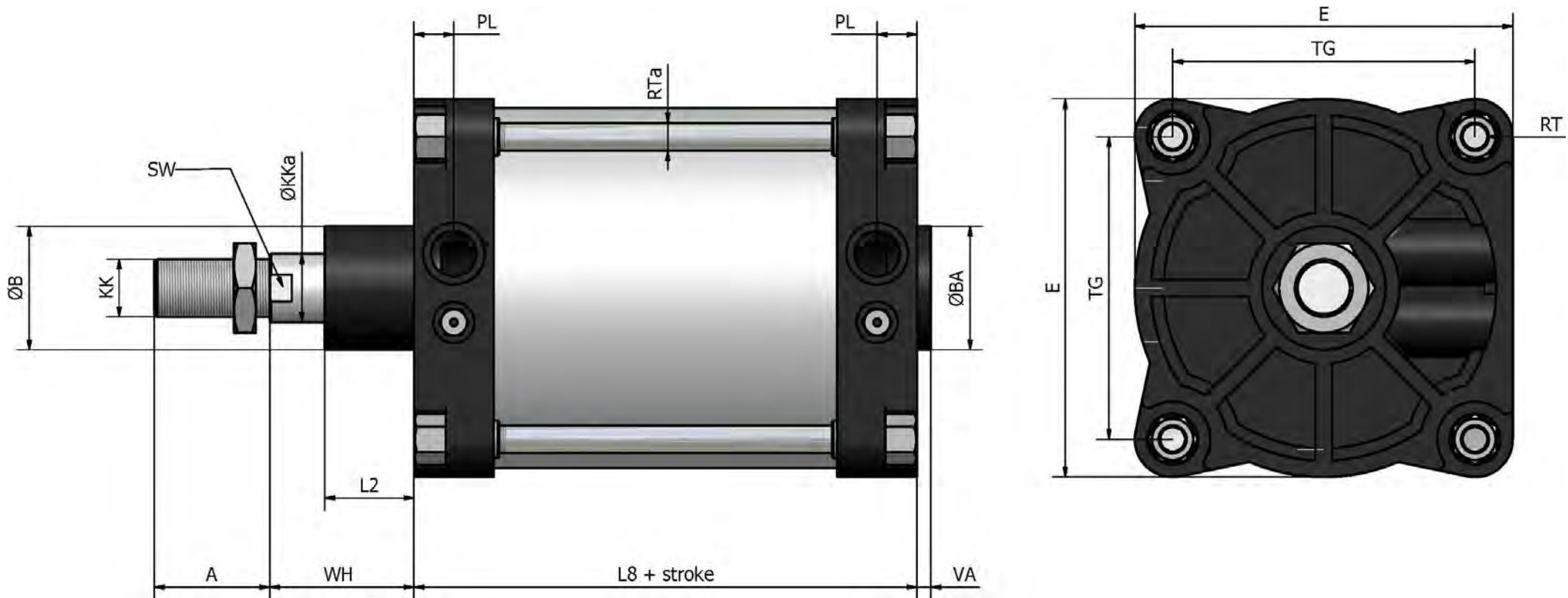

Cylinder ISO 15552 bore 250 - Dimensions

ØB	KKa	KK	SW	A	WH	L2	PL	RTa	L8	ØBA	VA	E	TG	RT
90	50	M42x2	46	84	105	65	29	20	200	90	10	275	220	M20 female

CERNIERA FEMMINA MP2 - FEMALE HINGE MP2

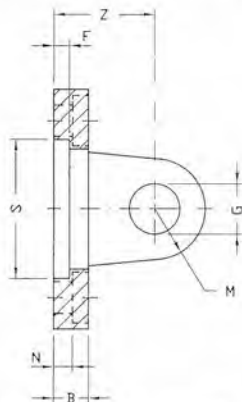
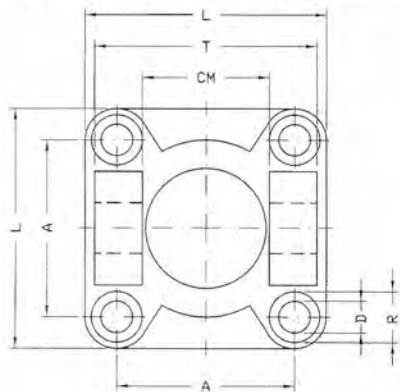

Materiale: acciaio A 105, stampato
Trattamento: cataforese nera

*Material: steel A 105, forged
Treatment: black cataphoresis*

Peso/ mass (g)	D.cil.	A ±0,2	L	D H 13	R H 13	N ±0,5	B	S H 11	F	Z ±0,2	G H 9	M max	CM H 14	T h 14
138	32	32,5	45	6,6	11	5,5	10	30	5	22	10	10	26	45
230	40	38	55	6,6	11	5,5	10	35	5	25	12	12	28	52
338	50	46,5	65	9	15	6,5	10	40	5	27	12	12	32	60
540	63	56,5	75	9	15	6,5	12	45	5	32	16	16	40	70
1000	80	72	95	11	18	10	14	45	=	36	16	16	50	90
1700	100	89	115	11	18	10	16	55	=	41	20	20	60	110
3350	125	110	140	13,5	20	10	20	60	=	50	25	25	70	130
5750	160	140	180	18	26	10	20	65	7	55	30	25	90	170
8900	200	175	220	18	26	11	20	75	7	60	30	25	90	170
15900	250	220	270 ± 2	22	33	11	25	90	11	70	40	40	110	200

Per ordinare / ordering

0017 / diam.

PIEDINO BASSO MS1 - LOW-RISE PEDESTAL MS1

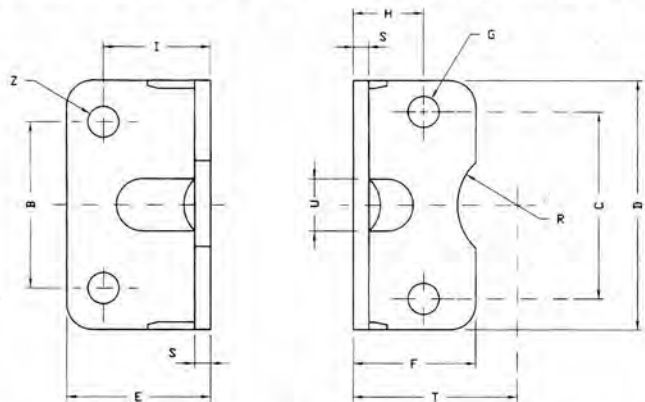

Materiale: Fe 37, tranciato e piegato
 Trattamento: Zincatura bianca o
 cataforese nera

*Material: Fe 37
 treatment: White zinc coating or black
 cataphoresis*

Peso/ mass(g)	D.Cil.	C ±0,2	B JS14	D 0 -0,2	E	F +2 0	G H 14	H ±0,2	I ±0,2	S ±0,5	T JS15	R H 15	U	Z H 14
66	32	32,5	32	45	35	30	7	15,75	24	4	32	15	11	7
78	40	38	36	52	36	30	7	17	28	4	36	17,5	15	9
168	50	46,5	45	65	47	36	9	21,75	32	5	45	20	16	9
190	63	56,5	50	75	45	35	9	21,75	32	5	50	22,5	18	9
382	80	72	63	95	55	47	11	27	41	6	63	22,5	17	12
452	100	89	75	115	57	53	11	26,5	41	6	71	27,5	24	14
1090	125	110	90	140	70	70	14	35	45	8	90	30	--	16
1188	160	140	115	180	75	100	18	45	60	9	115	32,5	--	18
3450	200	175	135	220	100	100	18	47,5	70	12	135	37,5	--	22
6600	250	220	165	270	100	150	22	55	75	14 ±1	165	45	--	26

Per ordinare / ordering

0006 / diam.

FLANGIA ISO MF1 / MF2 - FLANGE ISO MF1 / MF2

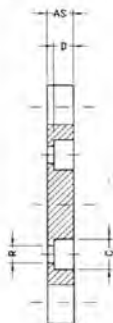
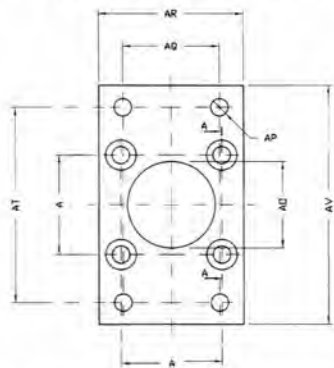

Materiale: Fe 37, Trafilato
 Trattamento: Zincatura bianca, a richiesta cataforese nera
 Per viti a testa normale a norma DIN 912

*Material: Fe 37
 Treatment: White zinc coating, on request black cataphoresis
 For screws to DIN 912 norm*

Peso/ mass(g)	D.cil.	A ± 0,2	AP H 13	AO H 11	R	AS ± 0,2	AR	AQ JS 14	AT JS 14	AV	C	D
190	32	32,5	7	30	6,5	10	45	32	64	80	10,5	6,5
246	40	38	9	35	6,5	10	52	36	72	90	10,5	6,5
478	50	46,5	9	40	8,5	12	65	45	90	110	13,5	8,5
622	63	56,5	9	45	8,5	12	75	50	100	120	13,5	8,5
1430	80	72	12	45	10,5	16	95	63	126	150	16,5	10,5
1986	100	89	14	55	10,5	16	115	75	150	170	16,5	10,5
3750	125	110	16	60	13,5	20	140	90	180	205	20	12,5
6350	160	140	18	65	17	20	180	115	230	260	25	16,5
11350	200	175	22	75	17	25	220	135	270	300	25	16,5
20100	250	220	26	90	22,5	25	285 ± 2	165	330	400 ± 2	33	20

Per ordinare / ordering

0008 / diam.

CERNIERA INTERMEDIA ROTONDA MT4 - INTERMEDIATE HINGE MT4

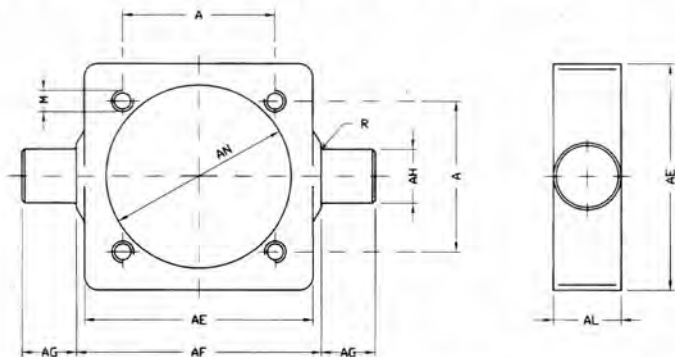

Materiale: Acciaio A 105, stampato
Trattamento: Zincatura bianca

*Material: steel A 105, forged
Treatment: White zinc coating*

Peso/ mass(g)	D.cil.	A ±0,2	AE max	AL max	AH e 9	AG h 14	AF h 14	AN ±0,2	R max	M
128	32	32,5	46	15	12	12	50	37	1	M6
308	40	38	59	20	16	16	63	46	1,5	M6
370	50	46,5	69	20	16	16	75	56	1,6	M8
690	63	56,5	84	25	20	20	90	69	1,6	M8
894	80	72	102	25	20	20	110	87	1,6	M10
1584	100	89	125	30	25	25	132	107	2	M10
2600	125	110	155	32	25	25	160	133	2	M12
4300	160	140	190	40	32	32	200	170	2,5	M16
7450	200	175	240	40	32	32	250	211	2,5	M16
13000	250	220	296	50	40	40	320	268	-	M20

Per ordinare / ordering

0009 / diam.

CERNIERA MASCHIO MP4 - MALE HINGE MP4

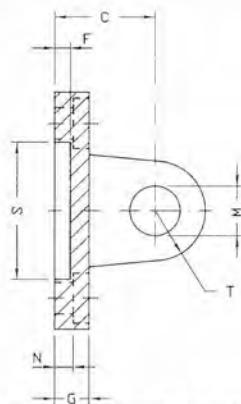
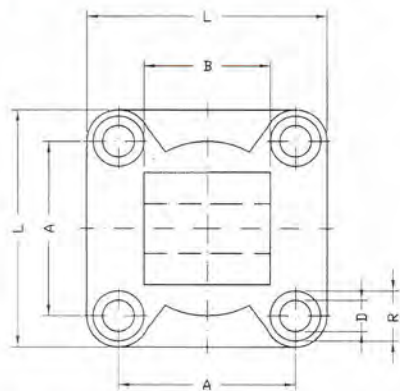

Materiale: acciaio A 105, stampato
Trattamento: cataforese nera

*Material: steel A 105, forged
Treatment: black cataphoresis*

Peso/ mass (g)	D.cil.	A ±0,2	L	D H 13	R H 13	N ±0,5	G	S H 11	F	C ±0,2	M H 9	T max	B
176	32	32,5	45	6,6	11	5,5	10	30	5	22	10	10	26
274	40	38	55	6,6	11	5,5	10	35	5	25	12	12	28
368	50	46,5	65	9	15	6,5	10	40	5	27	12	12	32
682	63	56,5	75	9	15	6,5	12	45	5	32	16	16	40
1196	80	72	95	11	18	10	14	45	5	36	16	16	50
2100	100	89	115	11	18	10	16	55	5	41	20	20	60
3740	125	110	140	13,5	20	10	20	60	7	50	25	25	70
5890	160	140	180	18	26	10	20	65	7	55	30	25	90
8470	200	175	220	18	26	11	20	75	7	60	30	25	90
16850	250	220	270 ± 2	22	33	11	25	90	11	70	40	40	110

-0,2
-0,6

-0,5
-1,2

Per ordinare / ordering

0019 / diam.

PERNO PER CERNIERA FEMMINA MP2 - PIVOT FOR FEMALE HINGE MP2

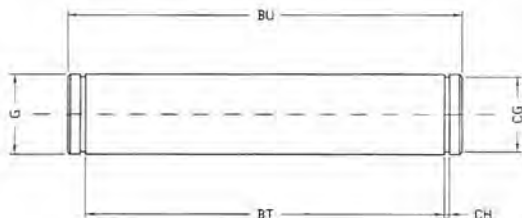

Materiale: acciaio AVP, rettificato
Trattamento: a richiesta brunitura o
zincatura bianca

*Material: steel AVP
treatment: on request burnishing or
white zinc coating*

Peso/ mass(g)	D.cil.	G 17	BT +0.3 0	CG	CH	BU
32	32	10	46	9,6	1,1	53
52	40	12	53	11,5	1,1	60
60	50	12	61	11,5	1,1	68
122	63	16	71	15,2	1,1	78
152	80	16	91	15,2	1,1	98
290	100	20	111	19	1,3	118
530	125	25	132	23,9	1,3	139
978	160	30	171,5	28,6	1,6	178
978	200	30	171,5	28,6	1,6	178
2100	250	40	202	37,5	1,6	211

Per ordinare / ordering

0007 / diam.